

SCHNITT A-A
MAßSTAB 1 : 1

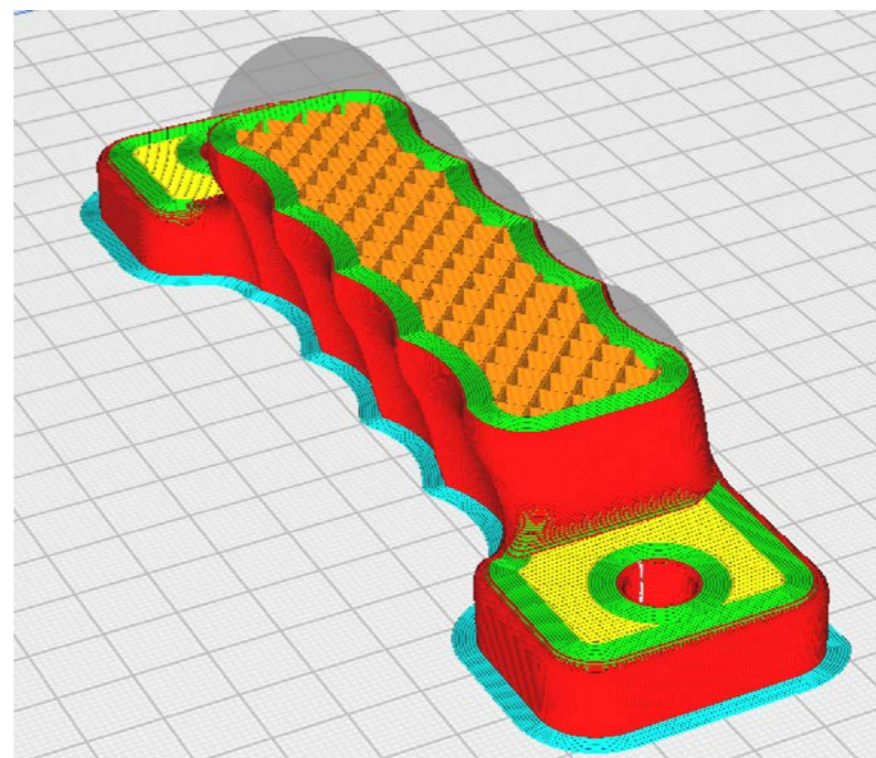

2 x ϕ 9,00 DURCH ALLES
 \surd ϕ 10,00 X 90°, Oben

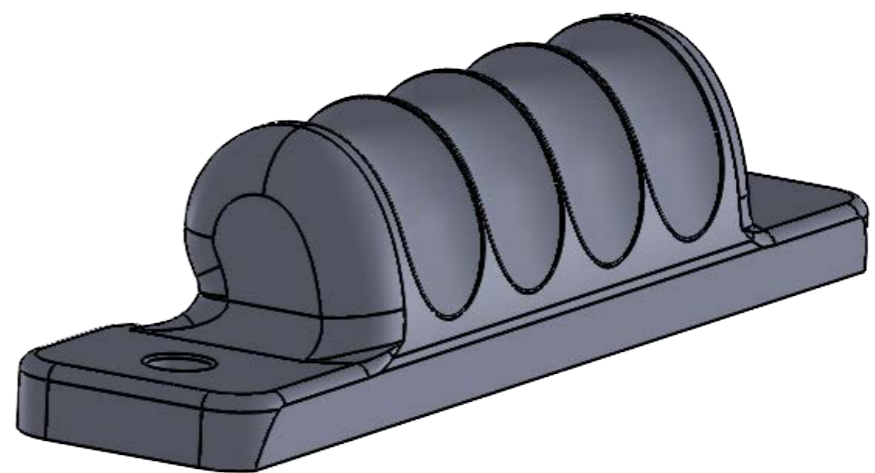
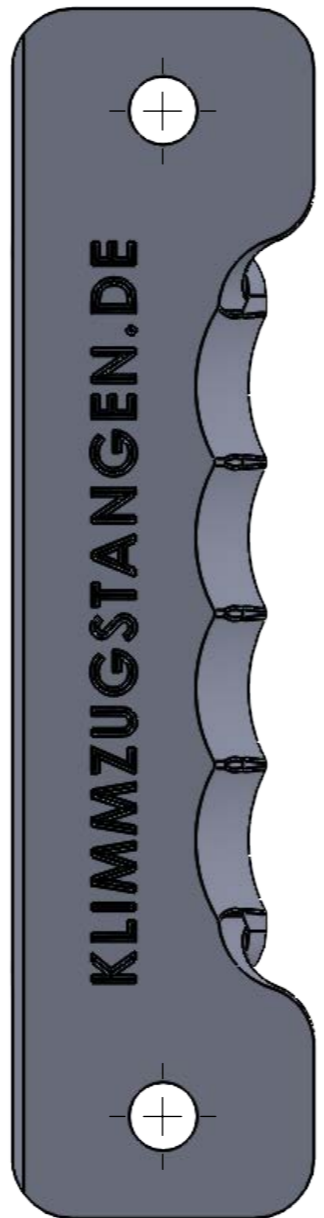
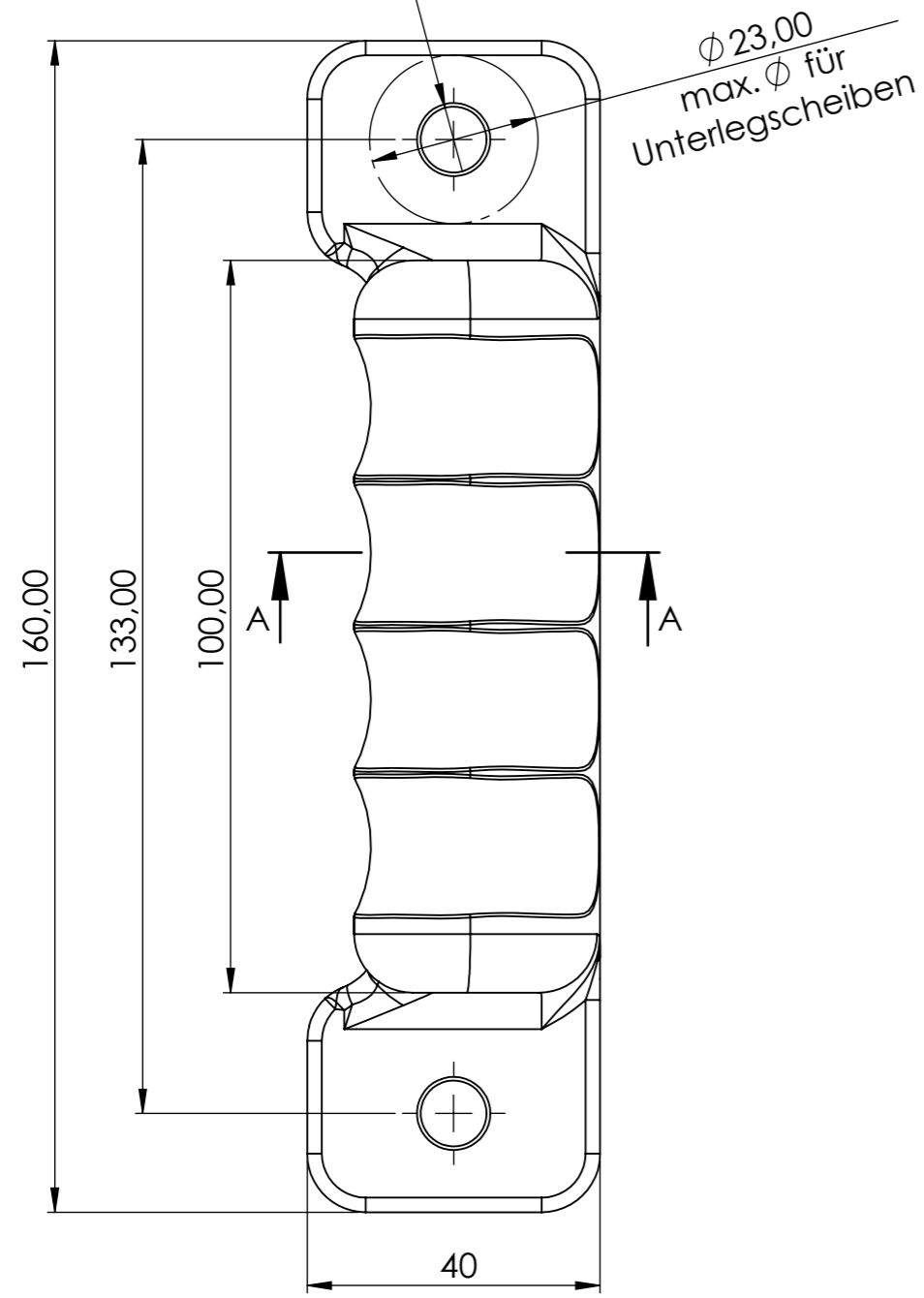

WENN NICHT ANDERS DEFINIERT: BEMASSUNGEN SIND IN MILLIMETER OBERFLÄCHENBESCHAFFENHEIT: TOLERANZEN: LINEAR: WINKEL:			OBERFLÄCHENGÜTE: Rz 120		ENTGRATEN UND SCHARFE KANTEN BRECHEN		ZEICHNUNG NICHT SKALIEREN		ÄNDERUNG				
							klimmzugstangen.de						
							BENENNUNG: Klimmzug-Henkel / Jugs J1						
							ZEICHNUNGSNR.						
							A3						
							WERKSTOFF: 3D Print - PLA		MASSTAB:1:2			BLATT 1 VON 1	
							GEWICHT: 100g						